

POWERPASTE

POWERPASTE FOR OFF-GRID POWER SUPPLY

POWERPASTE Key Facts

POWERPASTE is an ultra-high capacity hydrogen storage substance for PEM fuel cell applications invented and developed by Fraunhofer IFAM. POWERPASTE releases hydrogen on contact with water. It contains about 9 mass-% hydrogen (1 kg hydrogen = 9 kg POWERPASTE). This is a specific energy of 1600 Wh/kg and energy density of 1900 Wh/liter after conversion (10 times the capacity of Li-ion batteries). POWERPASTE is patented and offers many advantages over other energy storage technologies, in particular in the power range from 100 W to 10 kW:



No infrastructure necessary



Zero emission



Non-toxic



High power



Low TCO

Fuel Cell Power Generator

POWERPASTE releases hydrogen on-demand that can be consumed by any fuel cell. Apart from earlier portable power systems, a new 1000 W TRL 6 peak power stationary backup power generator has been demonstrated by Fraunhofer IFAM and GRÜNLAND Innovations GmbH. The power generator only consists of simple and inexpensive mechatronical and electrical components. The independent dosing of water and POWERPASTE ensures a highly controlled and safe hydrogen generation, which can be started and stopped at any time.

Applications

- Backup / emergency power
- Surveillance / security
- Light electric vehicles
- Construction sites
- Electric bicycles
- Drones
- Medical devices
- Self-sufficient generators
- Autonomous water vehicles
- Camping / outdoor equipment



Detailed Information

The technology is based on the chemical reaction between magnesium hydride, the main ingredient of POWERPASTE, and water. The reaction yields hydrogen and magnesium hydroxide as the only, non-toxic byproduct. Half of the produced hydrogen originates from the water, which is the reason for the ultra-high specific energy of POWERPASTE. Hydrogen generation with POWERPASTE is highly dynamic, while the material can still be safely handled.

Electricity is generated from POWERPASTE and water in a fully automated fuel cell-based power generator, which doses both materials to match the hydrogen demand of its fuel cell at any time. The power generator thus operates at low pressures and allows a safe and simple start-up, shut down and POWERPASTE cartridge change without tools and within seconds.



Fuel cell power generator

Next Steps

Fraunhofer is Europe's largest organization for applied research and development. We provide feasibility studies, market analyses as well as technology development from proof-of-principle up to market-readiness.

POWERPASTE technology allows tailored solutions for various specific power supply problems. If you are interested in POWERPASTE, please download our white paper „POWERPASTE for off-grid power supply“ for free and contact us directly at:

powerpaste@ifam-dd.fraunhofer.de

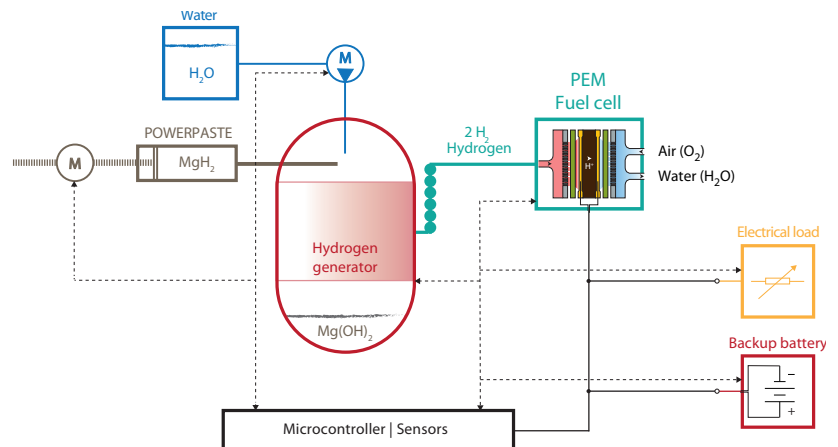

Schematic system diagram of a POWERPASTE + fuel cell power generator.

Dotted lines: sensors and controls.

Contact

Dr.-Ing. Felix Heubner
Phone: +49 351 2537 570

Dr. rer. nat. Marcus Vogt
Phone: +49 351 2537 413

Fraunhofer IFAM
Winterbergstraße 28
01277 Dresden
www.ifam.fraunhofer.de/en/powerpaste
www.ifam.fraunhofer.de/h2

**powerpaste@
ifam-dd.fraunhofer.de**

